

PRO-FORM®

CBC

Le Tour de France

Model No. PFEX39420-INT.0

Serial No. _____

Write the serial number in the space above for reference.

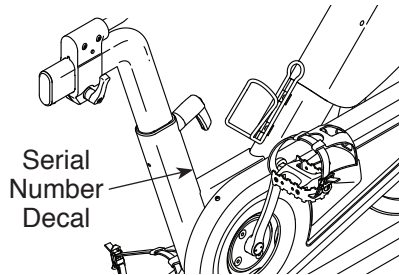

USER'S MANUAL

CUSTOMER SERVICE

UNITED KINGDOM

Call: 0330 123 1045

From Ireland: 053 92 36102

Website: iconsupport.eu

E-mail: csuk@iconeurope.com

Write:

ICON Health & Fitness, Ltd.

Unit 4, Westgate Court

Silkwood Park

OSSETT

WF5 9TT

UNITED KINGDOM

AUSTRALIA

Call: 1800 993 770

E-mail: australiacc@iconfitness.com

Write:

ICON Health & Fitness, Inc.

PO Box 635

WINSTON HILLS NSW 2153

AUSTRALIA

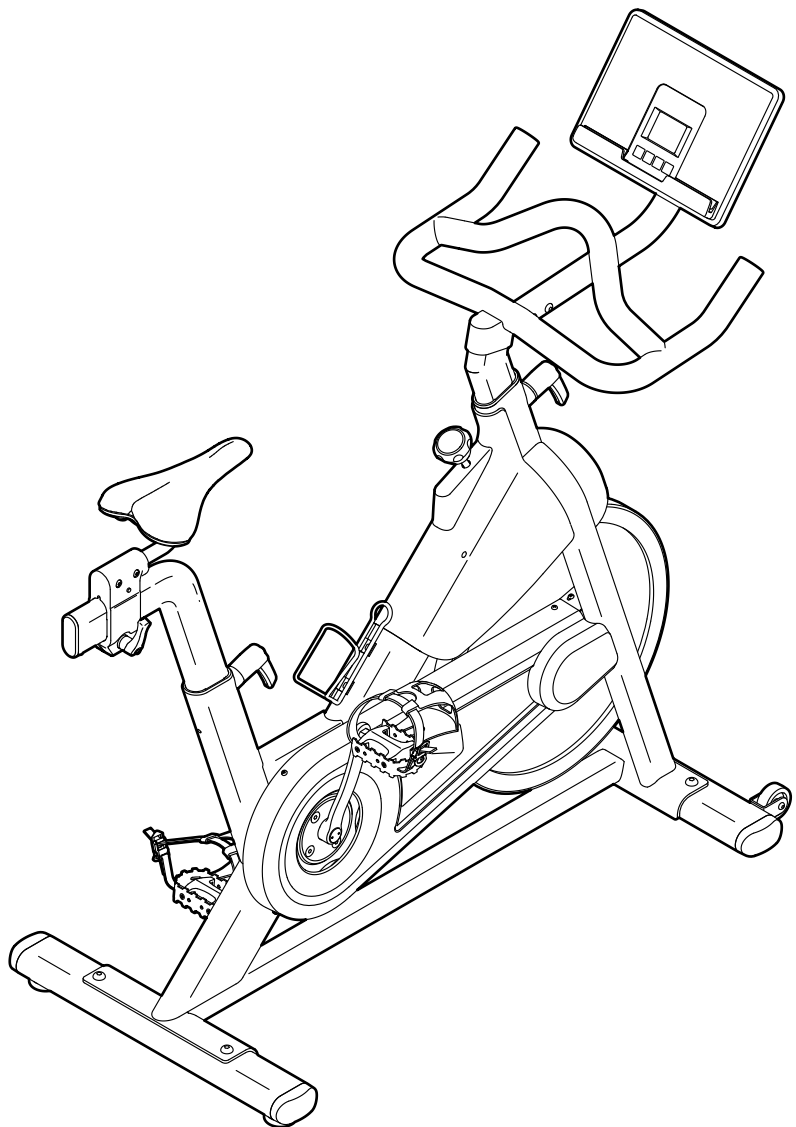

⚠ CAUTION

Read all precautions and instructions in this manual before using this equipment. Keep this manual for future reference.

iconeurope.com

TABLE OF CONTENTS

WARNING DECAL PLACEMENT	2
IMPORTANT PRECAUTIONS	3
BEFORE YOU BEGIN	4
PART IDENTIFICATION CHART	5
ASSEMBLY	6
HOW TO USE THE EXERCISE BIKE	14
HOW TO USE THE CONSOLE	16
MAINTENANCE AND TROUBLESHOOTING	21
EXERCISE GUIDELINES	23
PART LIST	25
EXPLODED DRAWING	26
ORDERING REPLACEMENT PARTS	Back Cover
RECYCLING INFORMATION	Back Cover

WARNING DECAL PLACEMENT

This drawing shows the location(s) of the warning decal(s). **If a decal is missing or illegible, see the front cover of this manual and request a free replacement decal. Apply the decal in the location shown.** Note: The decal(s) may not be shown at actual size.

⚠ WARNING

- Misuse of this bike may result in serious injury.
- Read user's manual prior to use and follow all warnings and instructions.
- Do not allow children on or around bike.
- Pedals continue to spin when you stop pedaling.
- Spinning pedals can cause injury.
- Reduce pedal speed in a controlled manner.
- Max user weight: 253 lbs/115 kg.
- Always use this bike on a level surface.
- This bike is not intended for therapeutic use.
- For safety, lock the bike when it is not in use.
- Replace label if damaged, illegible or removed.



⚠ WARNING



Keep hands and fingers clear of this area.

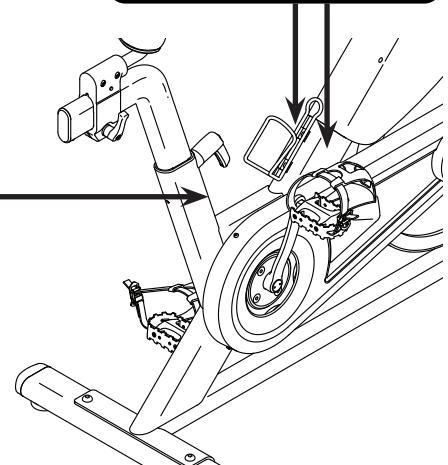

PROFORM and IFIT are registered trademarks of ICON Health & Fitness, Inc. App Store is a trademark of Apple Inc., registered in the U.S. and other countries. Android and Google Play are trademarks of Google LLC. The Bluetooth® word mark and logos are registered trademarks of Bluetooth SIG, Inc. and are used under license. IOS is a trademark or registered trademark of Cisco in the U.S. and other countries and is used under license.

IMPORTANT PRECAUTIONS

⚠️ WARNING: To reduce the risk of serious injury, read all important precautions and instructions in this manual and all warnings on your exercise bike before using your exercise bike. ICON assumes no responsibility for personal injury or property damage sustained by or through the use of this product.

1. It is the responsibility of the owner to ensure that all users of the exercise bike are adequately informed of all precautions.
2. Before beginning any exercise program, consult your physician. This is especially important for persons over age 35 or persons with pre-existing health problems.
3. The exercise bike is not intended for use by persons with reduced physical, sensory, or mental capabilities or lack of experience and knowledge, unless they are given supervision or instruction about use of the exercise bike by someone responsible for their safety.
4. Use the exercise bike only as described in this manual.
5. The exercise bike is intended for home use only. Do not use the exercise bike in a commercial, rental, or institutional setting.
6. Keep the exercise bike indoors, away from moisture and dust. Do not put the exercise bike in a garage or covered patio, or near water.
7. Place the exercise bike on a level surface, with a mat beneath it to protect the floor or carpet. Make sure that there is at least 2 ft. (0.6 m) of clearance around the exercise bike.
8. Inspect and properly tighten all parts each time the exercise bike is used. Replace any worn parts immediately.
9. Keep children under age 16 and pets away from the exercise bike at all times.
10. Wear appropriate clothes while exercising; do not wear loose clothes that could become caught on the exercise bike. Always wear athletic shoes for foot protection.
11. The exercise bike should not be used by persons weighing more than 253 lbs. (115 kg).
12. Be careful when mounting and dismounting the exercise bike.
13. Always keep your back straight while using the exercise bike; do not arch your back.
14. The exercise bike does not have a freewheel; the pedals will continue to move until the flywheel stops. Reduce your pedaling speed in a controlled way.
15. To stop the flywheel quickly, press the brake knob downward.
16. When the exercise bike is not in use, tighten the brake knob completely to prevent the flywheel from moving.
17. To avoid damaging the brake pads, do not lubricate the brake pads.
18. Over exercising may result in serious injury or death. If you feel faint, if you become short of breath, or if you experience pain while exercising, stop immediately and cool down.

BEFORE YOU BEGIN

Thank you for choosing the new PROFORM® LE TOUR DE FRANCE CBC exercise bike. Cycling is an effective exercise for increasing cardiovascular fitness, building endurance, and toning the body. The LE TOUR DE FRANCE CBC exercise bike provides a selection of features designed to make your workouts at home more effective and enjoyable.

For your benefit, read this manual carefully before you use the exercise bike. If you have questions after

reading this manual, please see the front cover of this manual. To help us assist you, note the product model number and serial number before contacting us. The model number and the location of the serial number decal are shown on the front cover of this manual.

Before reading further, please familiarize yourself with the parts that are labeled in the drawing below.

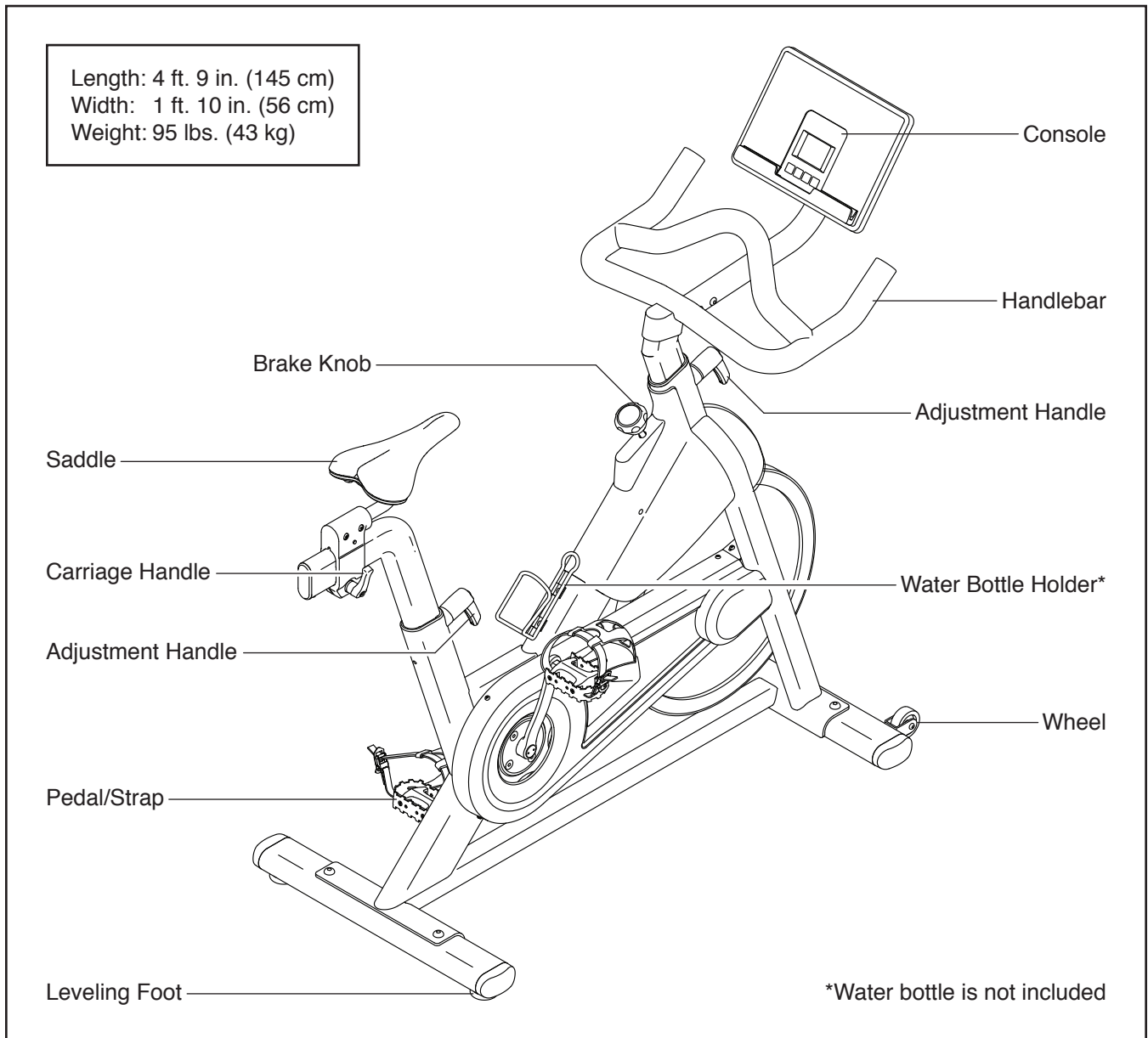

PART IDENTIFICATION CHART

Use the drawings below to identify the small parts needed for assembly. The number in parentheses below each drawing is the key number of the part, from the PART LIST near the end of this manual. The number following the key number is the quantity needed for assembly. **Note: If a part is not in the hardware kit, check to see if it has been preassembled. Extra parts may be included.**

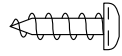

M4 x 12mm
Screw (81)-4

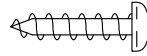

M4 x 16mm
Screw (11)-4

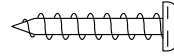

M4 x 20mm
Screw (87)-1

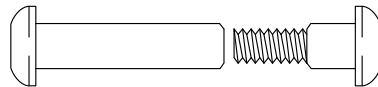

M6 Bolt Set (70)-2

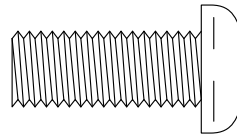

M10 x 25mm
Screw (69)-4

ASSEMBLY

- Assembly requires two persons.
- Place all parts in a cleared area and remove the packing materials. Do not dispose of the packing materials until you finish all assembly steps.
- Left parts are marked “L” or “Left” and right parts are marked “R” or “Right.”
- In addition to the included tool(s), assembly requires the following tool(s):

one Phillips screwdriver

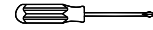

one adjustable wrench



one rubber mallet



one pair of scissors



Assembly may be easier if you have a set of wrenches. To avoid damaging parts, do not use power tools.

1. **To register your product and activate your warranty in the UK**, go to iconsupport.eu. If you do not have internet access, call Customer Service (see the front cover of this manual).

To register your product and activate your warranty in Australia, email or post the following information to the email address or postal address on the front cover of this manual.

- your receipt (make sure to keep a copy)
- your name, address, and telephone number
- the model number, serial number, and name of your product (see the front cover of this manual)

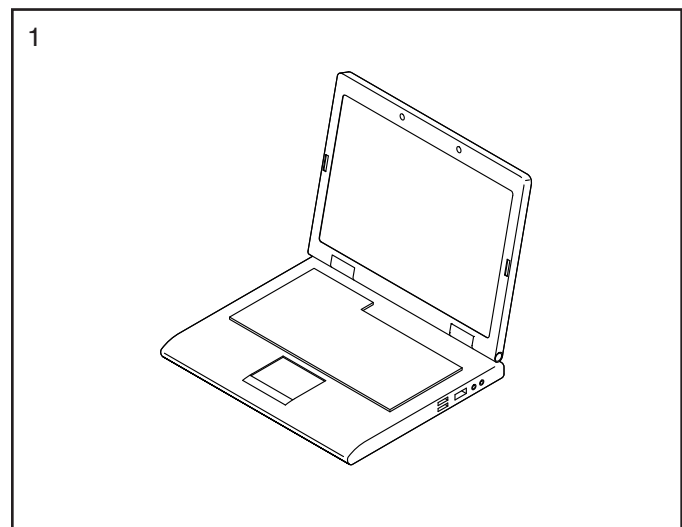

2. If there are shipping tubes (not shown) attached to the front and rear of the Frame (1), remove and discard the shipping tubes and the hardware attaching them.

Orient the Front Stabilizer (2) as shown, and attach it to the Frame (1) with two M10 x 25mm Screws (69).

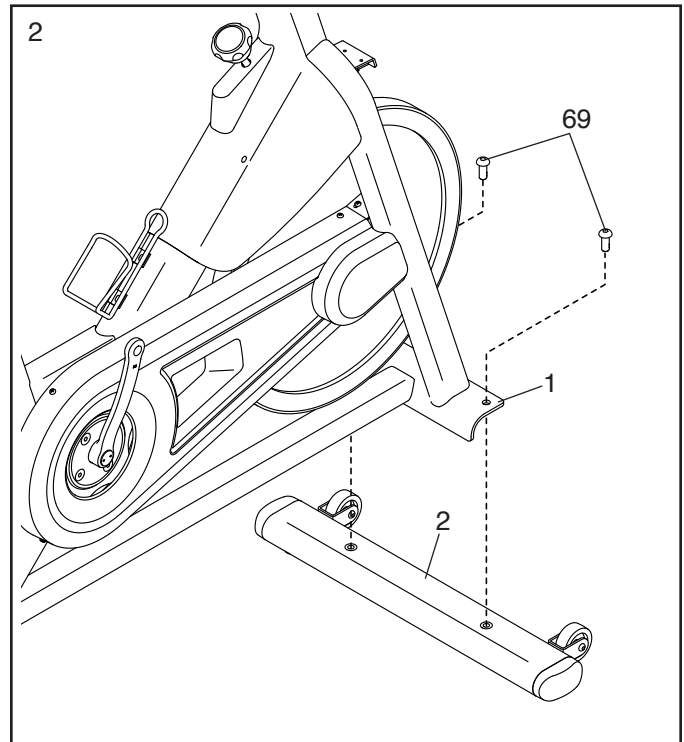

3. Attach the Rear Stabilizer (3) to the Frame (1) with two M10 x 25mm Screws (69).

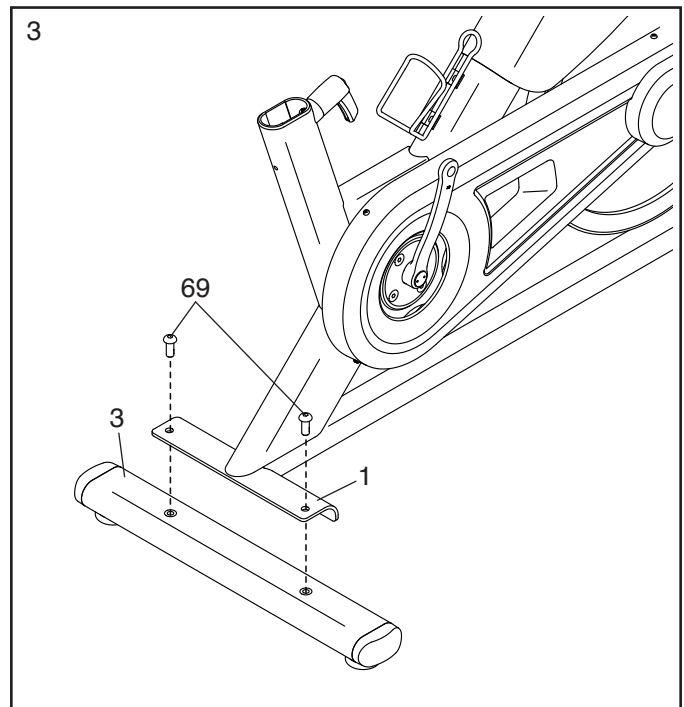

4. **Tip: See the inset drawing to learn how to operate the Adjustment Handle (14).**

Locate the Adjustment Handle (14) on the rear of the Frame (1). Pull the Adjustment Handle outward, and insert the Saddle Post (7) into the Frame.

Next, move the Saddle Post (7) upward or downward to the desired position, release the Adjustment Handle (14) into an adjustment hole in the Saddle Post, and then **tighten the Adjustment Handle four turns. Make sure that the Adjustment Handle is firmly engaged in an adjustment hole.**

Then, pull the Adjustment Handle (14) outward, turn it so that it points downward as shown, and then release it.

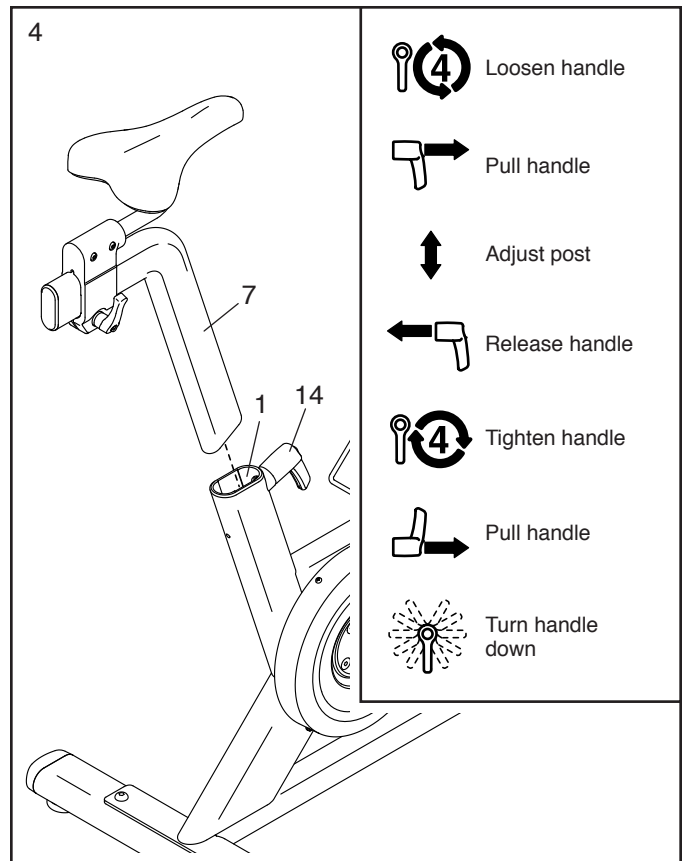

5. **Note: You can attach your own pedals if desired.**

Identify the Right Pedal (16). Using the included wrench, **firmly tighten** the Right Pedal **clockwise** into the Right Crank Arm (18).

Firmly tighten the Left Pedal (17) counterclockwise into the Left Crank Arm (not shown). IMPORTANT: You must turn the Left Pedal counterclockwise to attach it.

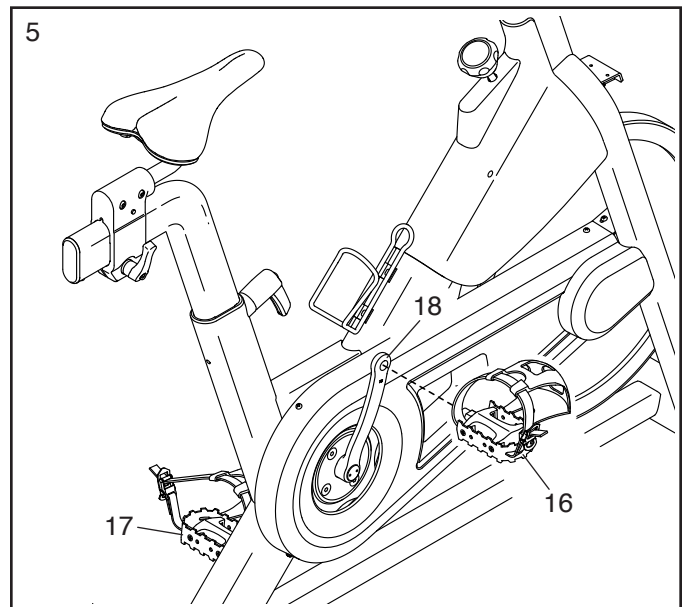

6. Have a second person hold the Handlebar (4) near the Frame (1).

Next, locate the wire tie (A) in the Frame (1). Tie the wire tie to the Upper Wire (90) in the Handlebar (4). Then, pull the lower end of the wire tie until the Upper Wire is routed through the Frame. Untie and discard the wire tie.

Tip: See the upper inset drawing to learn how to operate the Adjustment Handle (14).

Next, locate the Adjustment Handle (14) on the front of the Frame (1). Pull the Adjustment Handle outward. Then, insert the Handlebar (4) into the Frame.

Move the Handlebar (4) downward and release the Adjustment Handle (14) into the indicated adjustment hole (B). Then, tighten the Adjustment Handle four turns. **Make sure that the Adjustment Handle is firmly engaged in the adjustment hole.**

Then, pull the Adjustment Handle (14) outward, turn it so that it points downward as shown, and then release it.

See the lower inset drawing. Insert the Upper Wire (90) through the zip tie (C) on the Frame (1); **do not connect the Upper Wire and do not tighten the zip tie yet.**

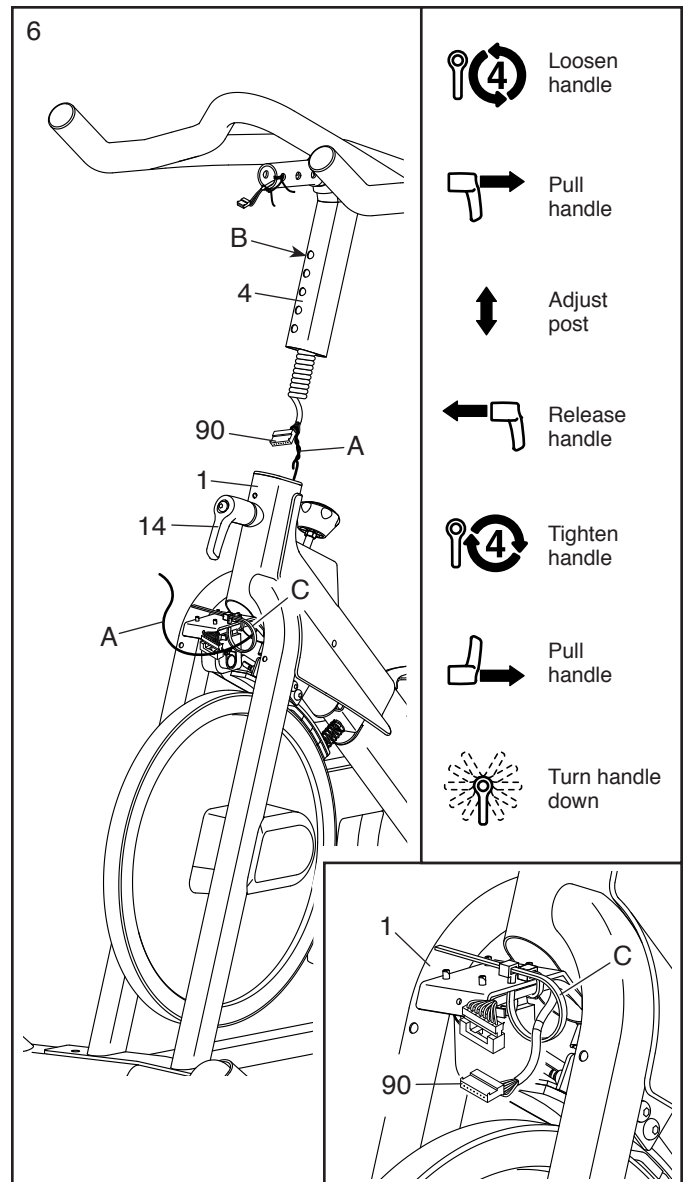

7. **See the inset drawing.** Connect the connector on the Upper Wire (90) to the connector on the Lower Wire (82).

Next, tighten the zip tie (C) around the indicated mark (D) on the Upper Wire (90). Then, cut off the excess zip tie.

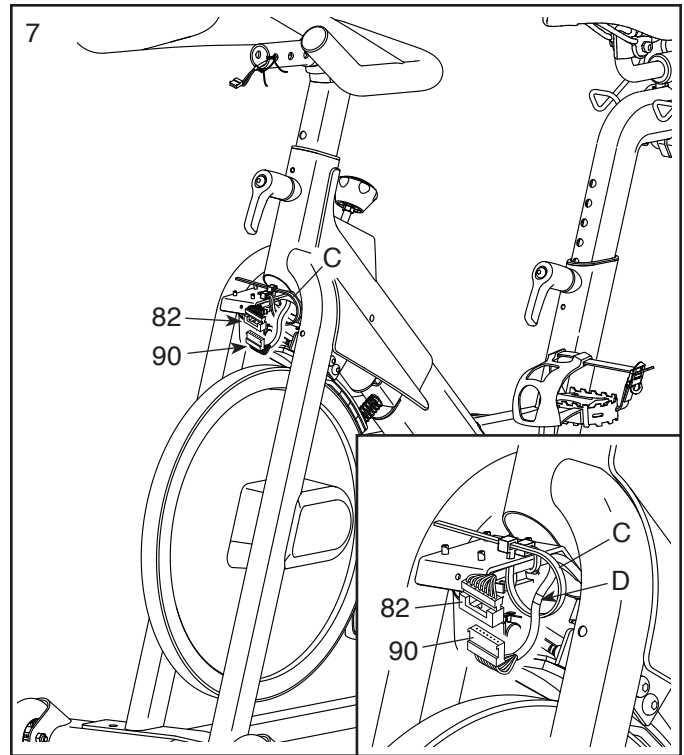

8. **Tip: Avoid pinching the wires.** Press the Motor Cover (38) onto the Frame (1), and then attach it with an M4 x 20mm Screw (87).

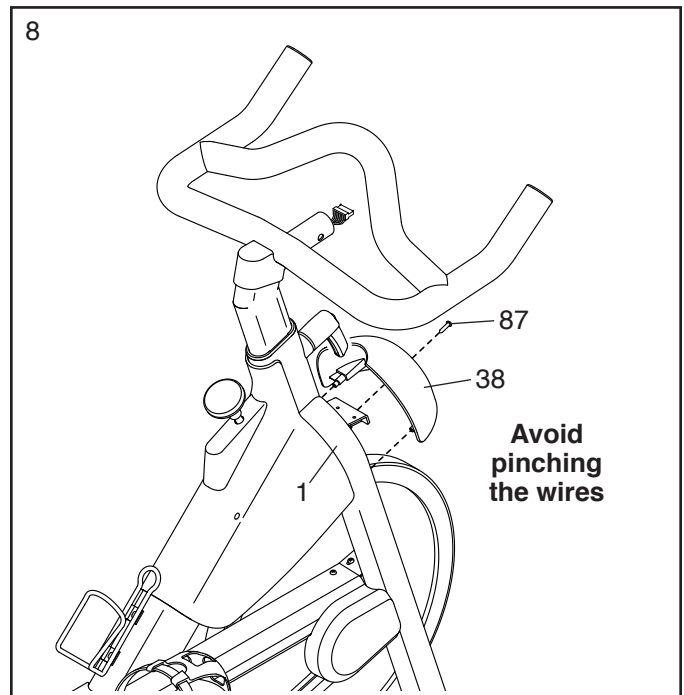

9. Untie the wire tie (E) holding the Upper Wire (90) to the Handlebar (4).

While a second person holds the Console Mount (5) near the Handlebar (4), connect the Extension Wire (12) in the Console Mount to the Upper Wire (90) in the Handlebar (4).

Tip: Avoid pinching the wires. Gently pull on the indicated wire tie (F) as you slide the Console Mount (5) onto the Handlebar (4). Continue to pull the wire tie until the Extension Wire (12) is routed through the Console Mount. **Make sure that the wires inside the Handlebar are out of the way of the bolt holes.**

You can attach the Console Mount (5) in either the standard position or the extended position. For the standard position, align the Console Mount with the inner holes (G, H). For the extended position, align the Console Mount with the outer holes (H, I).

Tip: Avoid pinching the wires. Attach the Console Mount (5) with two M6 Bolt Sets (70).

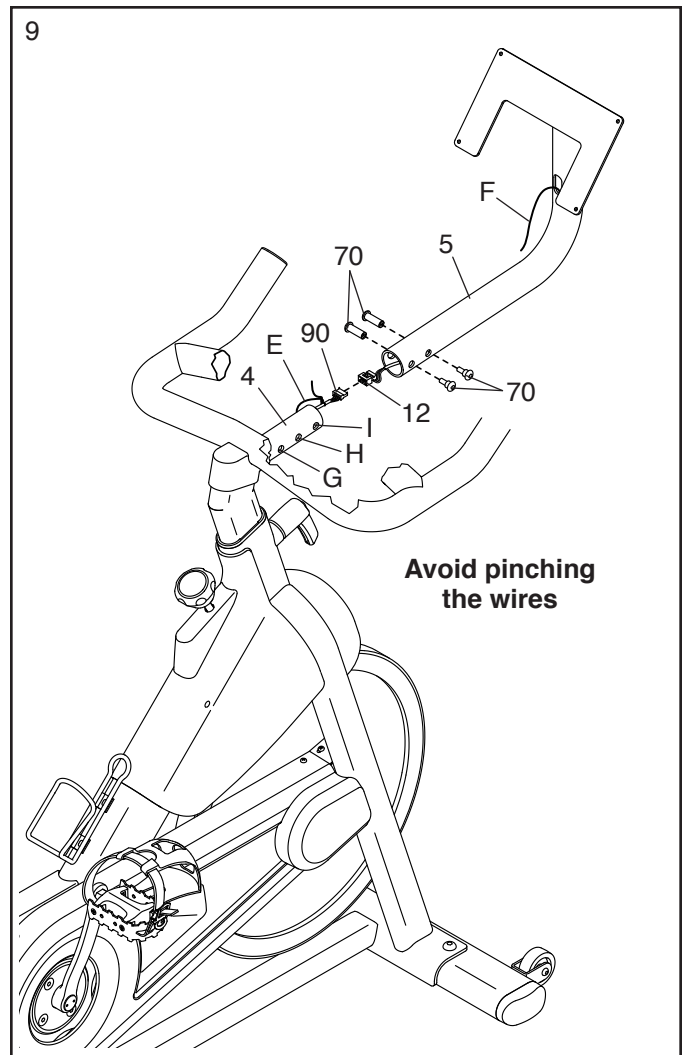

10. **IMPORTANT: Do not insert batteries into the Console (6) until instructed to do so in assembly step 14. If batteries are inserted before the Console Wire (J) is connected, the Console will not function properly.**

Orient the Console (6) and the Console Housing (86) as shown. Slide the Console into the Console Housing.

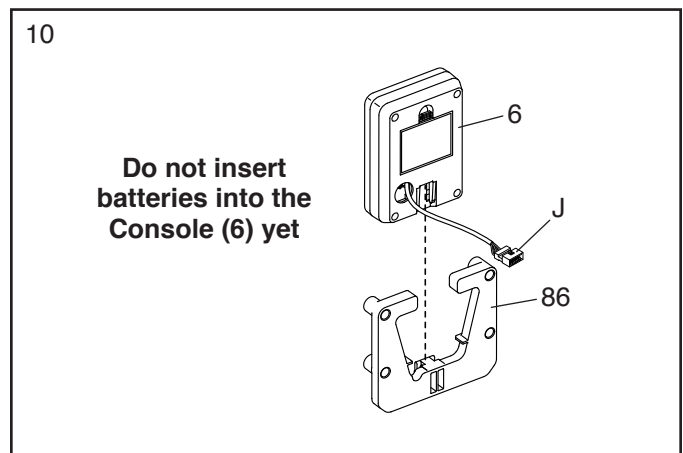

11. Orient the Console Housing (86) and the Console Deck (89) as shown.

Attach the Console Housing (86) to the Console Deck (89) with four M4 x 16mm Screws (11); **start all the Screws, and then tighten them.**

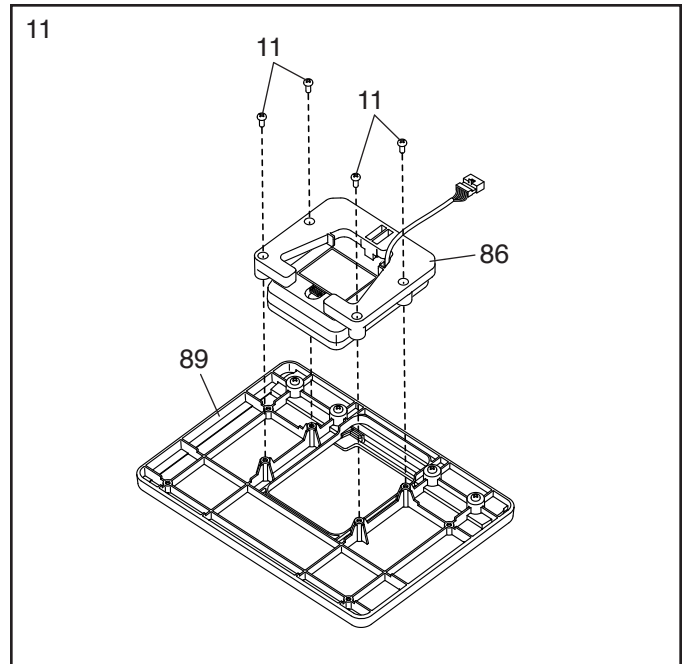

12. While a second person holds the Console Deck (89) near the Console Mount (5), connect the Console Wire (J) to the Extension Wire (12).

Next, press the Wire Protector (59) around the Console Wire (J) in the location shown.

Then, insert the Wires (J, 12) into the Console Mount (5), and press the Wire Protector (59) into the Console Mount.

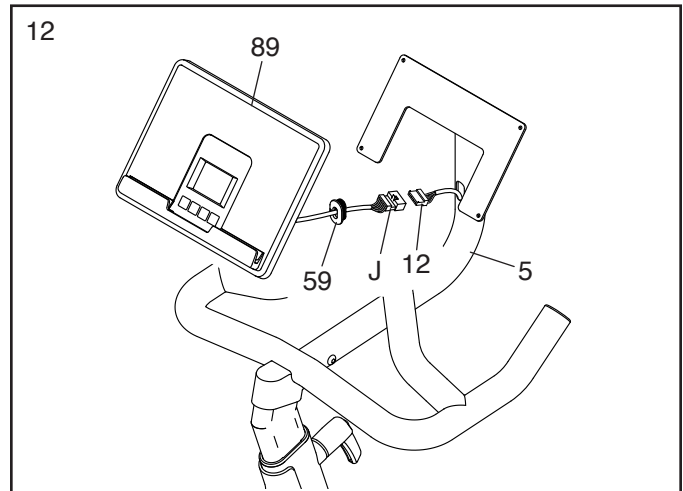

13. **Tip: Avoid pinching the wires. If necessary, tilt the Console Bracket (26) upward to make this step easier.** Attach the Console Deck (89) to the Console Bracket with four M4 x 12mm Screws (81); **start all the Screws, and then tighten them.**

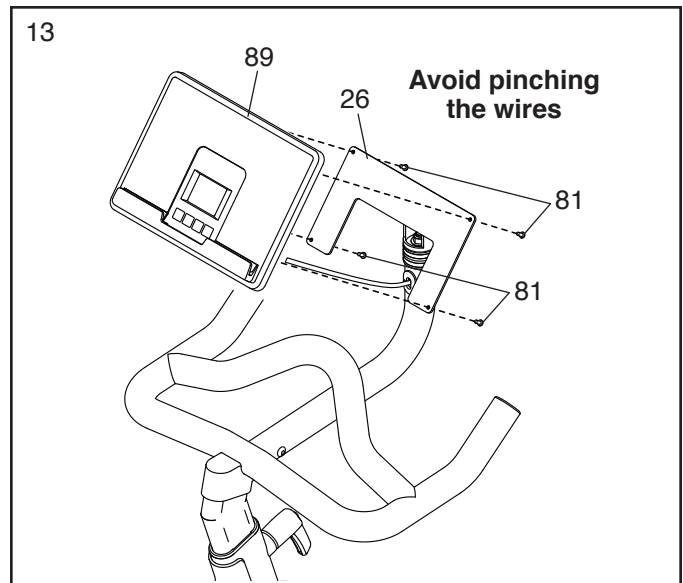

14. The Console (6) requires three AA batteries (not included); alkaline batteries are recommended. Do not use old and new batteries together or alkaline, standard, and rechargeable batteries together. **IMPORTANT: If the Console has been exposed to cold temperatures, allow it to warm to room temperature before you insert batteries. Otherwise, you may damage the console displays or other electronic components.**

See the inset drawing. Press the tab on the battery cover (K), and remove the battery cover. Next, insert three batteries into the battery compartment; **make sure to orient the batteries as shown by the diagram inside the battery compartment.** Then, reattach the battery cover.

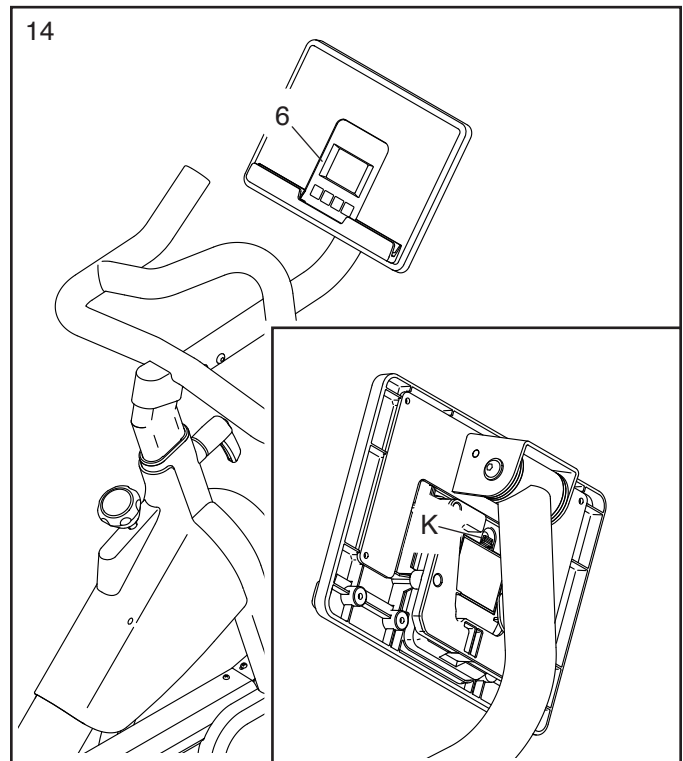

15. **After the exercise bike is assembled, inspect it to make sure that it is assembled correctly, that it functions properly, and that all parts are properly tightened.** Extra parts may be included. Place a mat under the exercise bike to protect the floor or carpet.

HOW TO USE THE EXERCISE BIKE

HOW TO LEVEL THE EXERCISE BIKE

If the exercise bike rocks slightly on your floor during use, turn one or both of the leveling feet (A) beneath the rear stabilizer until the rocking motion is eliminated.

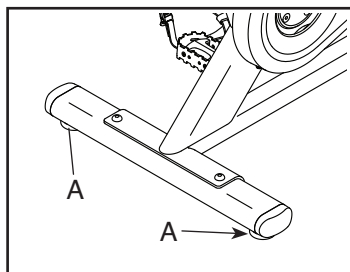

Note: The carriage handle (C) functions like a ratchet. You can turn the carriage handle in the desired direction, pull it outward, turn it in the opposite direction, push it inward, and then turn it in the desired direction again. You can repeat this process as many times as desired.

HOW TO ADJUST THE SADDLE POST

For effective exercise, the saddle should be at the proper height. As you pedal, there should be a slight bend in your knees when the pedals are in the lowest position.

HOW TO ADJUST THE ANGLE OF THE SADDLE

You can adjust the angle of the saddle to the position that is most comfortable. You can also slide the saddle forward or backward to increase your comfort or to adjust the distance to the handlebar.

To adjust the saddle, loosen the nuts (B) on the saddle clamp a few turns, and then tilt the saddle upward or downward or slide the saddle forward or backward to the desired position. Then, retighten the nuts.

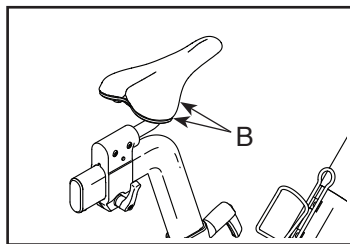

To adjust the height of the saddle post, first loosen the adjustment handle (D) four turns and pull it outward. Next, move the saddle post upward or downward, release the adjustment handle into an adjustment hole in the saddle post, and firmly tighten the adjustment handle four turns.

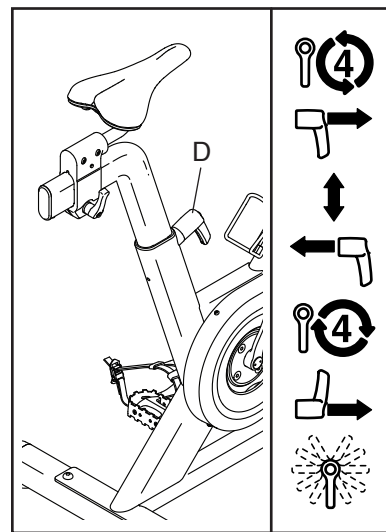

HOW TO ADJUST THE HORIZONTAL POSITION OF THE SADDLE

To adjust the position of the saddle, loosen the carriage handle (C) a few turns, and then move the saddle forward or backward to the desired position. Then, firmly tighten the carriage handle.

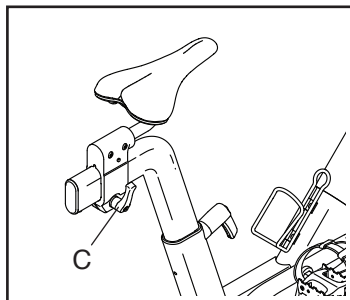

Make sure that the adjustment handle is engaged in an adjustment hole. Then, pull the adjustment handle outward, turn it so that it points downward as shown, and then release it.

HOW TO ADJUST THE HANDLEBAR

To adjust the height of the handlebar, first loosen the adjustment handle (E) four turns and pull it outward. Then, move the handlebar upward or downward, release the adjustment handle into an adjustment hole in the handlebar, and firmly tighten the adjustment handle four turns.

Make sure that the adjustment handle is engaged in an adjustment hole. Then, pull the adjustment handle outward, turn it so that it points downward as shown, and then release it.

To adjust the horizontal position of the handlebar, see assembly step 9 on page 11.

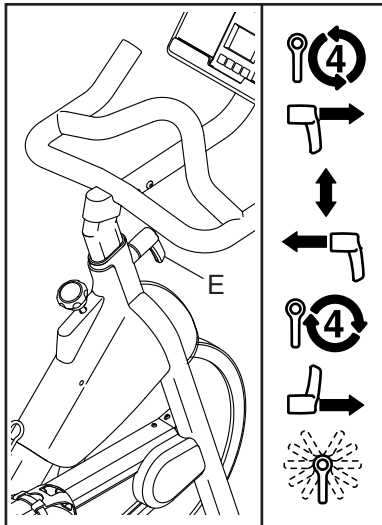

HOW TO USE THE PEDALS

To use the pedals (F), insert your shoes into the toe cages and pull the ends of the toe straps. To adjust the toe straps, press and hold the tabs on the buckles, adjust the toe straps to the desired position, and then release the tabs.

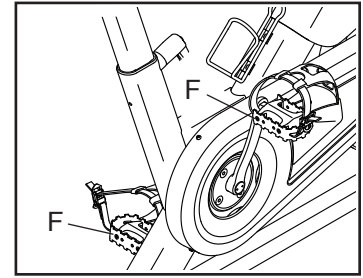

Note: You can attach your own pedals to the exercise bike if desired.

HOW TO USE THE BRAKE KNOB

To change the resistance of the pedals, press the buttons on the console (see step 2 on page 17). To stop the flywheel, push the brake knob (G) downward. The flywheel should quickly come to a complete stop.

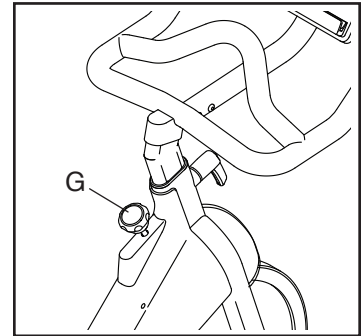

IMPORTANT: When the exercise bike is not in use, tighten the brake knob (G) completely.

HOW TO USE THE CONSOLE

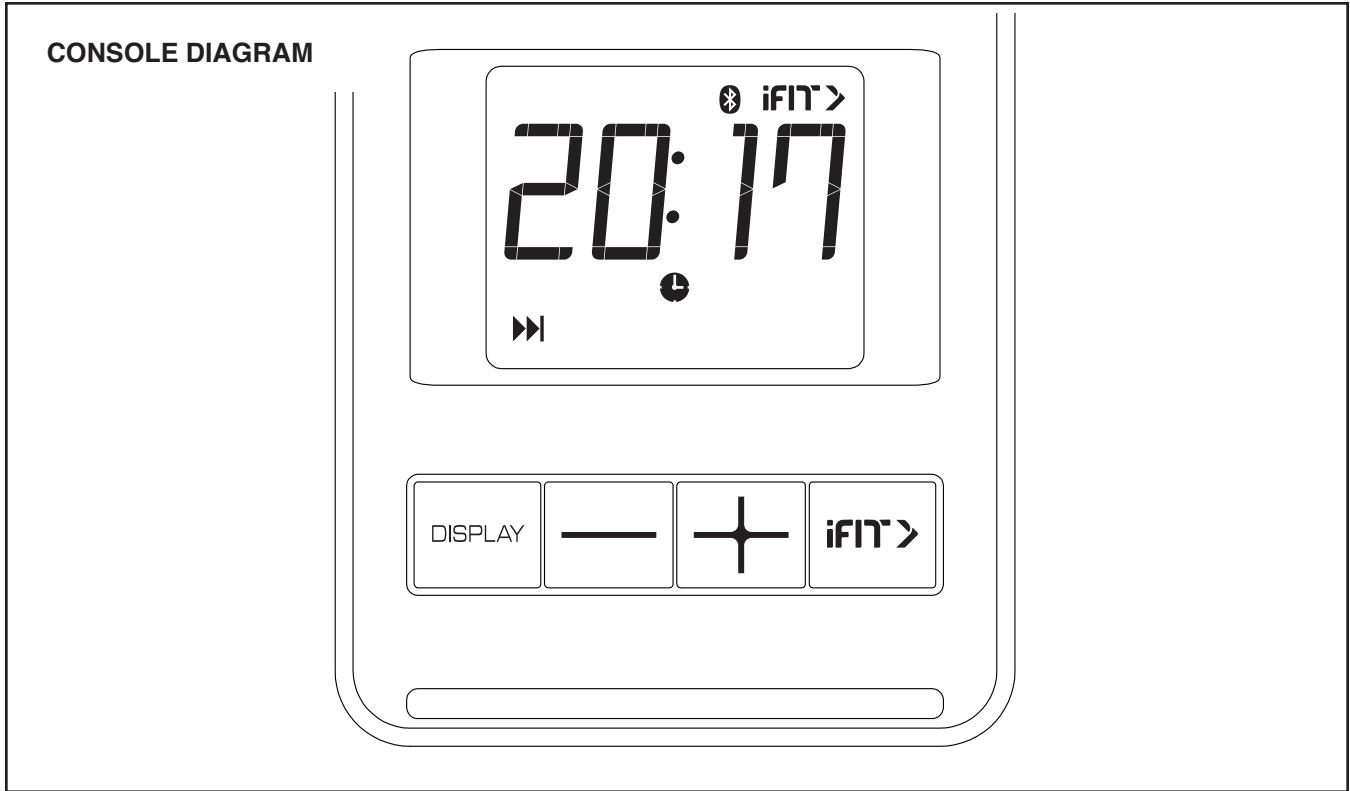

FEATURES OF THE CONSOLE

The easy-to-use console enables you to change the resistance of the pedals with the touch of a button and provides instant exercise feedback during your workouts.

You can also measure your heart rate using an optional heart rate monitor. **See page 20 for information about purchasing an optional chest heart rate monitor.**

You can also connect your tablet to the console and use the iFit® app to record and track your workout information.

To use the manual mode, see page 17. **To connect your tablet to the console,** see page 19. **To connect your heart rate monitor to the console,** see page 20.

Note: If there is a sheet of plastic on the display, remove the plastic.

HOW TO USE THE MANUAL MODE

1. Begin pedaling or press any button on the console to turn on the console.

When you turn on the console, the display will turn on. The console will then be ready for use.

2. Change the resistance of the pedals as desired.

As you pedal, change the resistance of the pedals by pressing the increase and decrease buttons.

Note: After you press a button, it will take a moment for the pedals to reach the selected resistance level.

If the message CH0 or CH1 appears in the display when you press the increase and decrease buttons, you must recalibrate the resistance system. First, see assembly step 14 on page 13 and remove the batteries from the console. Next, press and hold any button on the console for 20 seconds. Then, release the button and reinsert the batteries into the console; the exercise bike will adjust to the lowest resistance level.

3. Follow your progress with the display.

The display can show the following workout information:

Scan (scan arrow icon)—This mode displays the speed, pulse, calories, resistance, RPM, time, and distance modes, for a few seconds each, in a repeating cycle.

Speed (rabbit icon)—This mode displays your pedaling speed, in kilometers per hour.

Pulse (heart icon)—This mode displays your heart rate in beats per minute when you are using an optional heart rate monitor (see step 4).

Calories (flame icon)—This mode displays the approximate number of calories that you have burned during your workout.

Resistance (hand weight icon)—This mode displays the current resistance level of the pedals.

RPM (circular arrow icon)—This mode displays your pedaling speed, in revolutions per minute (RPM).

Time (clock icon)—This mode displays the elapsed time that you have pedaled during your workout.

Distance (road icon)—This mode displays the distance that you have pedaled during your workout, in kilometers.

Scan mode—When the console is turned on, the scan mode will automatically be selected. **The scan arrow icon (A) will appear in the display when the scan mode is selected.** Note: If a different mode is selected, select the scan mode again by pressing the Display button repeatedly.

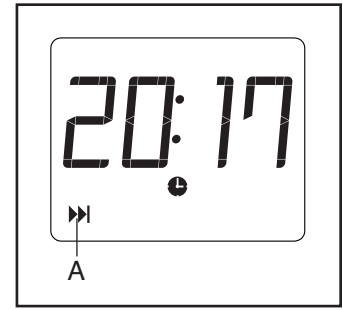

Speed, pulse, calories, resistance, RPM, time, and distance mode—To select one of these modes for continuous display, press the Display button repeatedly.

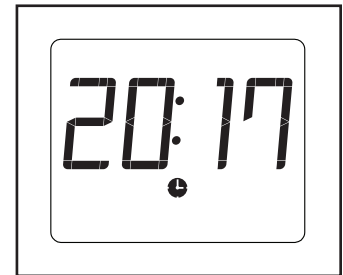

The mode icons will show which mode is selected. **Make sure that there the scan arrow icon does not appear.**

To pause the console, simply stop pedaling. The console will pause for up to a few minutes. To continue your workout, simply resume pedaling.

To end your workout and reset the display to zero, simply stop pedaling and wait for a few minutes for the console display to reset.

4. Wear a heart rate monitor and measure your heart rate if desired.

You can wear an optional heart rate monitor to measure your heart rate. **For more information about the optional heart rate monitor, see page 20.** Note: The console is compatible with Bluetooth® Smart heart rate monitors.

To connect your heart rate monitor to the console, see HOW TO CONNECT YOUR HEART RATE MONITOR TO THE CONSOLE on page 20.

If your heart rate is not shown, make sure that the pulse mode is displayed.

5. When you are finished exercising, the console will turn off automatically.

The console has an auto-off feature. If the pedals are not moved and the console buttons are not pressed for a few minutes, the console will turn off automatically.

IMPORTANT: When you are finished exercising, make sure to disconnect your tablet and/or heart rate monitor from the console (see this page and page 20). If you do not do this, the console may not turn off and the batteries will drain more quickly.

HOW TO CONNECT YOUR TABLET TO THE CONSOLE

The console supports Bluetooth connections to tablets via the iFit app and to compatible heart rate monitors. Note: Other Bluetooth connections are not supported.

1. Download and install the iFit app on your tablet.

On your iOS® or Android™ tablet, open the App StoreSM or the Google Play™ store, search for the free iFit app, and then install the app on your tablet. **Make sure that the Bluetooth option is enabled on your tablet.**

Then, open the iFit app and follow the instructions to set up an iFit account and customize settings.

2. Connect your heart rate monitor to the console if desired.

If you are connecting both your heart rate monitor and your tablet to the console, **you must connect your heart rate monitor before you connect your tablet.** See HOW TO CONNECT YOUR HEART RATE MONITOR TO THE CONSOLE on page 20.

3. Connect your tablet to the console.

Press the iFit button on the console; the console pairing number will appear in the display. Then, follow the instructions in the iFit app to connect your tablet to the console. When the your tablet is connected, the Bluetooth icon will appear in the display.

4. Record and track your workout information.

Follow the instructions in the iFit app to record and track your workout information.

5. Disconnect your tablet from the console if desired.

To disconnect your tablet from the console, first select the disconnect option in the iFit app. Then, press and hold the iFit button on the console.

Note: All Bluetooth connections between the console and other devices (including any tablets, heart rate monitors, and so forth) will be disconnected.

HOW TO CONNECT YOUR HEART RATE MONITOR TO THE CONSOLE

The console is compatible with all Bluetooth Smart heart rate monitors.

To connect your Bluetooth Smart heart rate monitor to the console, press the iFit button on the console; the console pairing number will appear in the display. When your heart rate monitor is connected, the Bluetooth icon will appear in the display.

Note: If there is more than one compatible heart rate monitor near the console, the console will connect to the heart rate monitor with the strongest signal.

To disconnect your heart rate monitor from the console, press and hold the iFit button on the console.

Note: All Bluetooth connections between the console and other devices (including any tablets, heart rate monitors, and so forth) will be disconnected.

THE OPTIONAL CHEST HEART RATE MONITOR

Whether your goal is to burn fat or to strengthen your cardiovascular system, the key to achieving the best results is to maintain the proper heart rate during your workouts.

The optional chest heart rate monitor will enable you to continuously monitor your heart rate while you exercise, helping you to reach your personal fitness goals. **To purchase a chest heart rate monitor, please see the front cover of this manual.**

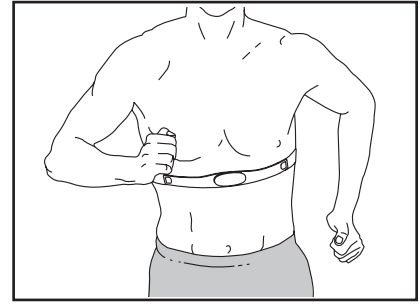

Note: The console is compatible with all Bluetooth Smart heart rate monitors.

MAINTENANCE AND TROUBLESHOOTING

HOW TO MAINTAIN THE EXERCISE BIKE

Regular maintenance is important for optimal performance and to reduce wear. Inspect and properly tighten all parts each time the exercise bike is used. Replace any worn parts immediately.

To clean the exercise bike, use a damp cloth and a small amount of mild detergent. **IMPORTANT: To avoid damage to the console, keep liquids away from the console and keep the console out of direct sunlight.**

HOW TO TROUBLESHOOT THE CONSOLE

If the console display becomes dim, replace the batteries (see assembly step 14 on page 13); most console problems are the result of low batteries.

If the exercise bike will not be used for an extended period of time, remove the batteries from the console.

If the message CH0 or CH1 appears in the display when you press the increase and decrease buttons, you must recalibrate the resistance system. First, see assembly step 14 on page 13 and remove the batteries from the console. Next, press and hold any button on the console for 20 seconds. Then, release the button and reinsert the batteries into the console; the exercise bike will adjust to the lowest resistance level.

HOW TO TROUBLESHOOT THE TABLET HOLDER

If the tablet holder does not stay in place, rotate the tablet holder backward and tighten the locknut (A) inside the bracket mount until the tablet holder stays in place when it is rotated to the desired position.

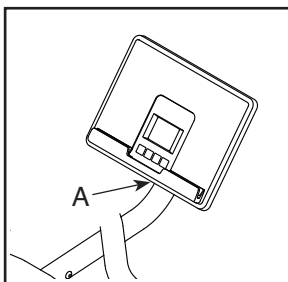

HOW TO ADJUST THE REED SWITCH

If the console does not display correct feedback, the reed switch should be adjusted.

To adjust the reed switch, locate the Reed Switch (57) on the left side of the exercise bike. Slightly loosen the two M4 x 20mm Screws (87).

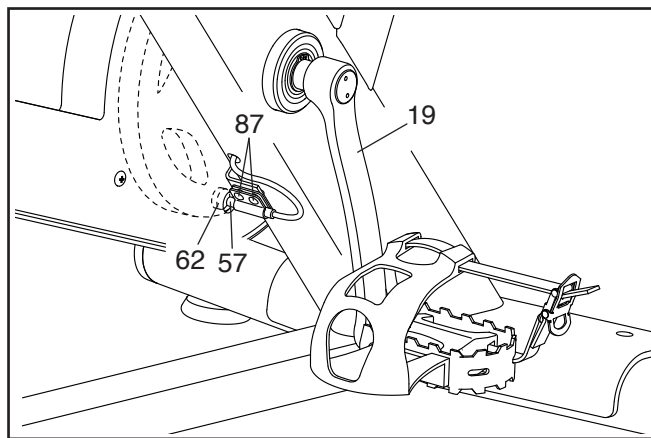

Next, turn the Left Crank Arm (19) until a Magnet (62) is aligned with the Reed Switch (57). Slide the Reed Switch slightly toward or away from the Magnet. Then, retighten the M4 x 20mm Screws (87).

Turn the Left Crank Arm (19) for a moment. Repeat the procedure above, if necessary, until the console displays correct feedback.

HOW TO ADJUST THE DRIVE BELT

If you feel the pedals slip while you are pedaling, even when the resistance is adjusted to the highest level, the drive belt may need to be adjusted.

To adjust the drive belt, locate the Idler Cover (36). Remove the M4 x 12mm Blunt Screw (80) and the Idler Cover.

Then, tighten the M10 x 60mm Screw (65) until the Drive Belt (not shown) is tight.

When the Drive Belt (not shown) is tight, reattach the Idler Cover (36).

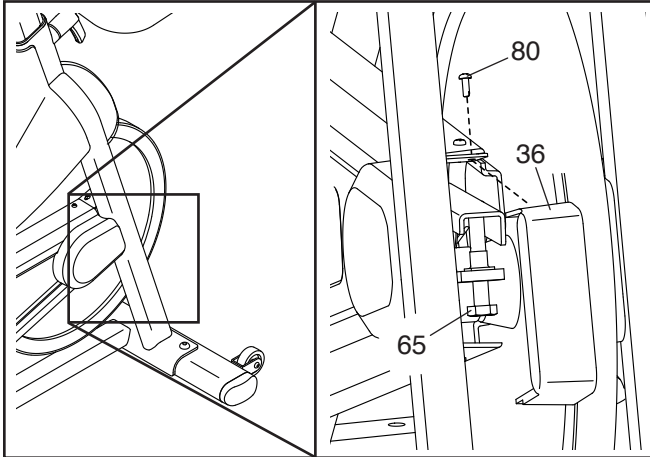

EXERCISE GUIDELINES

⚠️ WARNING: Before beginning this or any exercise program, consult your physician. This is especially important for persons over age 35 or persons with pre-existing health problems.

These guidelines will help you to plan your exercise program. For detailed exercise information, obtain a reputable book or consult your physician. Remember, proper nutrition and adequate rest are essential for successful results.

EXERCISE INTENSITY

Whether your goal is to burn fat or to strengthen your cardiovascular system, exercising at the proper intensity is the key to achieving results. You can use your heart rate as a guide to find the proper intensity level. The chart below shows recommended heart rates for fat burning and aerobic exercise.

165	155	145	140	130	125	115	♥️
145	138	130	125	118	110	103	♥️
125	120	115	110	105	95	90	♥️
<hr/>							
20	30	40	50	60	70	80	

To find the proper intensity level, find your age at the bottom of the chart (ages are rounded off to the nearest ten years). The three numbers listed above your age define your “training zone.” The lowest number is the heart rate for fat burning, the middle number is the heart rate for maximum fat burning, and the highest number is the heart rate for aerobic exercise.

Burning Fat—To burn fat effectively, you must exercise at a low intensity level for a sustained period of time. During the first few minutes of exercise, your body uses carbohydrate calories for energy. Only after the first few minutes of exercise does your body begin to use stored fat calories for energy. If your goal is to burn fat, adjust the intensity of your exercise until your heart rate is near the lowest number in your training zone. For maximum fat burning, exercise with your heart rate near the middle number in your training zone.

Aerobic Exercise—If your goal is to strengthen your cardiovascular system, you must perform aerobic exercise, which is activity that requires large amounts of oxygen for prolonged periods of time. For aerobic exercise, adjust the intensity of your exercise until your heart rate is near the highest number in your training zone.

HOW TO MEASURE YOUR HEART RATE

To measure your heart rate, exercise for at least four minutes. Then, stop exercising and place two fingers on your wrist as shown. Take a six-second heartbeat count, and multiply the result by 10 to find your heart rate. For example, if your six-second heartbeat count is 14, your heart rate is 140 beats per minute.

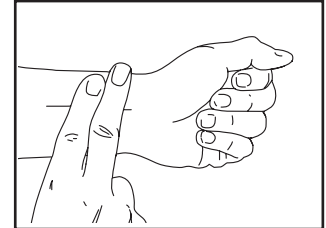

WORKOUT GUIDELINES

Warming Up—Start with 5 to 10 minutes of stretching and light exercise. A warm-up increases your body temperature, heart rate, and circulation in preparation for exercise.

Training Zone Exercise—Exercise for 20 to 30 minutes with your heart rate in your training zone. (During the first few weeks of your exercise program, do not keep your heart rate in your training zone for longer than 20 minutes.) Breathe regularly and deeply as you exercise; never hold your breath.

Cooling Down—Finish with 5 to 10 minutes of stretching. Stretching increases the flexibility of your muscles and helps to prevent post-exercise problems.

EXERCISE FREQUENCY

To maintain or improve your condition, complete three workouts each week, with at least one day of rest between workouts. After a few months of regular exercise, you may complete up to five workouts each week, if desired. Remember, the key to success is to make exercise a regular and enjoyable part of your everyday life.

SUGGESTED STRETCHES

The correct form for several basic stretches is shown at the right. Move slowly as you stretch; never bounce.

1. Toe Touch Stretch

Stand with your knees bent slightly and slowly bend forward from your hips. Allow your back and shoulders to relax as you reach down toward your toes as far as possible. Hold for 15 counts, then relax. Repeat 3 times. Stretches: Hamstrings, back of knees and back.

2. Hamstring Stretch

Sit with one leg extended. Bring the sole of the opposite foot toward you and rest it against the inner thigh of your extended leg. Reach toward your toes as far as possible. Hold for 15 counts, then relax. Repeat 3 times for each leg. Stretches: Hamstrings, lower back and groin.

3. Calf/Achilles Stretch

With one leg in front of the other, reach forward and place your hands against a wall. Keep your back leg straight and your back foot flat on the floor. Bend your front leg, lean forward and move your hips toward the wall. Hold for 15 counts, then relax. Repeat 3 times for each leg. To cause further stretching of the achilles tendons, bend your back leg as well. Stretches: Calves, achilles tendons and ankles.

4. Quadriceps Stretch

With one hand against a wall for balance, reach back and grasp one foot with your other hand. Bring your heel as close to your buttocks as possible. Hold for 15 counts, then relax. Repeat 3 times for each leg. Stretches: Quadriceps and hip muscles.

5. Inner Thigh Stretch

Sit with the soles of your feet together and your knees outward. Pull your feet toward your groin area as far as possible. Hold for 15 counts, then relax. Repeat 3 times. Stretches: Quadriceps and hip muscles.

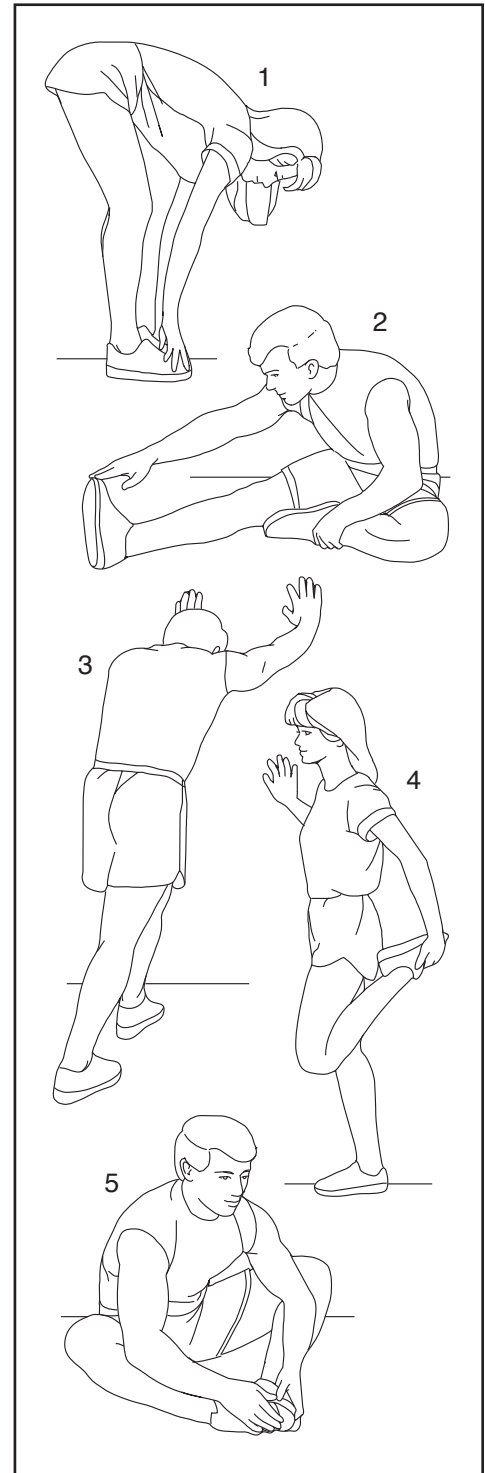

PART LIST

Model No. PFEX39420-INT.0 R0820A

Key No.	Qty.	Description	Key No.	Qty.	Description
1	1	Frame	49	2	Flywheel Bearing
2	1	Front Stabilizer	50	1	Flywheel Spacer
3	1	Rear Stabilizer	51	2	Wheel
4	1	Handlebar	52	2	Foot
5	1	Console Mount	53	2	Leveling Foot
6	1	Console	54	4	Cap
7	1	Saddle Post	55	1	Saddle Post Cap
8	1	Saddle	56	2	Inner Pivot Disc
9	1	Saddle Arm	57	1	Reed Switch/Wire
10	1	Saddle Carriage	58	1	Clamp
11	4	M4 x 16mm Screw	59	1	Wire Protector
12	1	Extension Wire	60	1	Flywheel Washer
13	1	Carriage Handle	61	4	Clip Nut
14	2	Adjustment Handle	62	2	Magnet
15	1	Water Bottle Holder	63	4	M8 x 20mm Flat Head Screw
16	1	Right Pedal	64	7	M8 Locknut
17	1	Left Pedal	65	1	M10 x 60mm Screw
18	1	Crank/Right Crank Arm	66	1	Crank Screw
19	1	Left Crank Arm	67	1	Bracket Spacer
20	1	Resistance Cable	68	1	M10 Locknut
21	1	Resistance Bracket	69	4	M10 x 25mm Screw
22	1	Resistance Spring	70	2	M6 Bolt Set
23	1	Resistance Magnet	71	2	Outer Pivot Disc
24	1	Resistance Motor	72	2	M8 x 45mm Bolt
25	1	Brake Knob	73	2	M6 x 45mm Shoulder Screw
26	1	Console Bracket	74	4	M4 x 10mm Screw
27	1	Brake Shaft	75	2	M12 Locknut
28	1	Brake Spring	76	1	M5 x 35mm Bolt
29	1	Brake Bracket	77	1	M5 Locknut
30	2	Brake Spacer	78	1	Brake Bushing
31	1	Idler	79	6	M6 x 12mm Screw
32	1	Cover Bracket	80	11	M4 x 12mm Blunt Screw
33	1	Right Hub Cover	81	4	M4 x 12mm Screw
34	1	Outer Belt Cover	82	1	Lower Wire
35	1	Inner Belt Cover	83	1	M8 x 80mm Bolt
36	1	Idler Cover	84	1	Ground Screw
37	1	Left Hub Cover	85	2	M12 Nut
38	1	Motor Cover	86	1	Console Housing
39	1	Brake Cover	87	15	M4 x 20mm Screw
40	1	Saddle Post Sleeve	88	2	M4 x 19mm Flange Screw
41	1	Handlebar Sleeve	89	1	Console Deck
42	2	Crank Arm Cap	90	1	Upper Wire
43	2	Snap Ring	91	2	M8 Washer
44	2	Crank Bearing	92	1	Brake Shaft End
45	1	Pulley	93	1	Hairpin Cotter Pin
46	1	Drive Belt	94	1	Brake Washer
47	1	Flywheel	*	–	Assembly Tool
48	1	Flywheel Axle	*	–	User's Manual

Note: Specifications are subject to change without notice. For information about ordering replacement parts, see the back cover of this manual. *These parts are not illustrated.

EXPLODED DRAWING A

Model No. PFEX39420-INT.0 R0820A

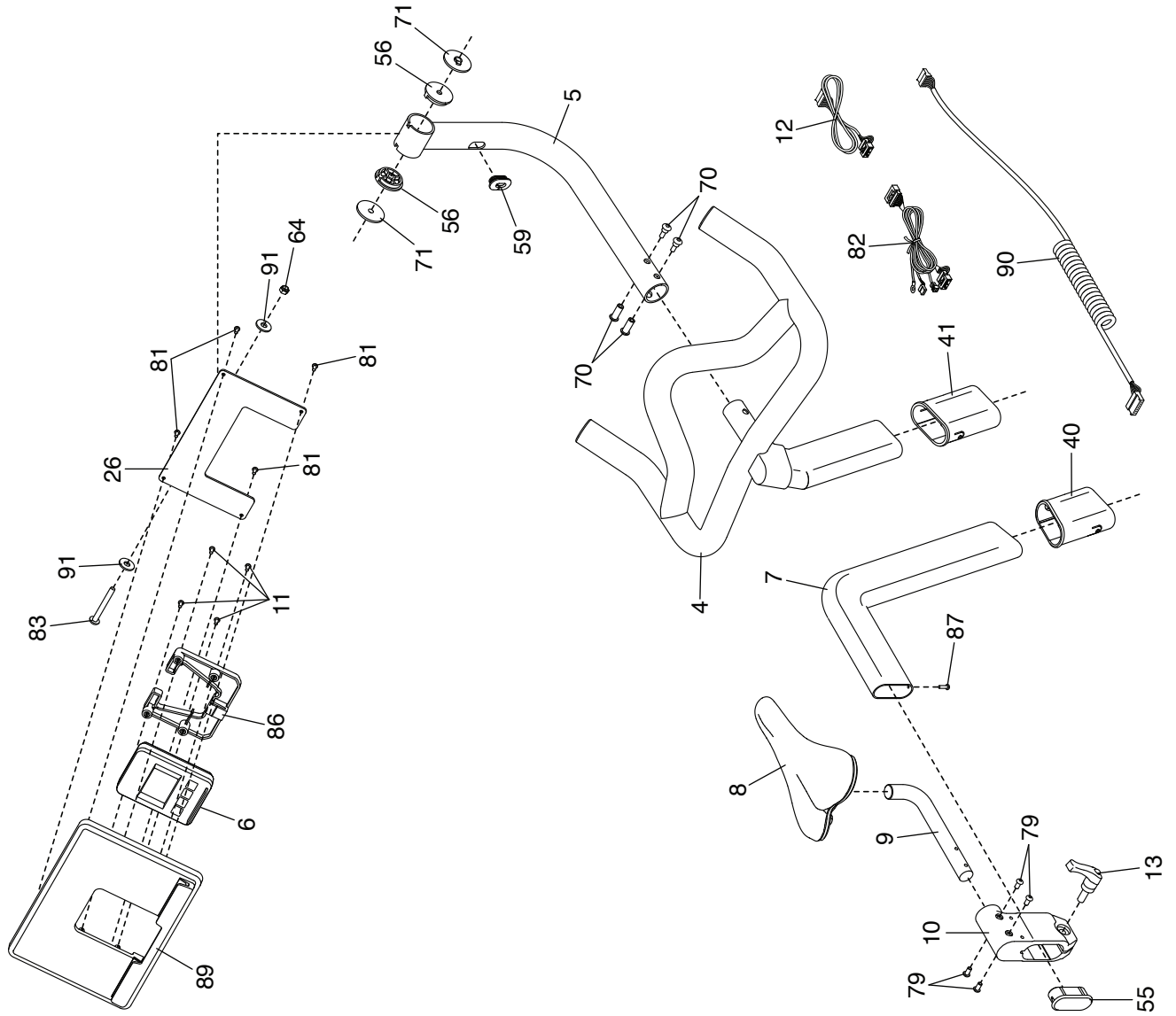

EXPLODED DRAWING B

Model No. PFEX39420-INT.0 R0820A

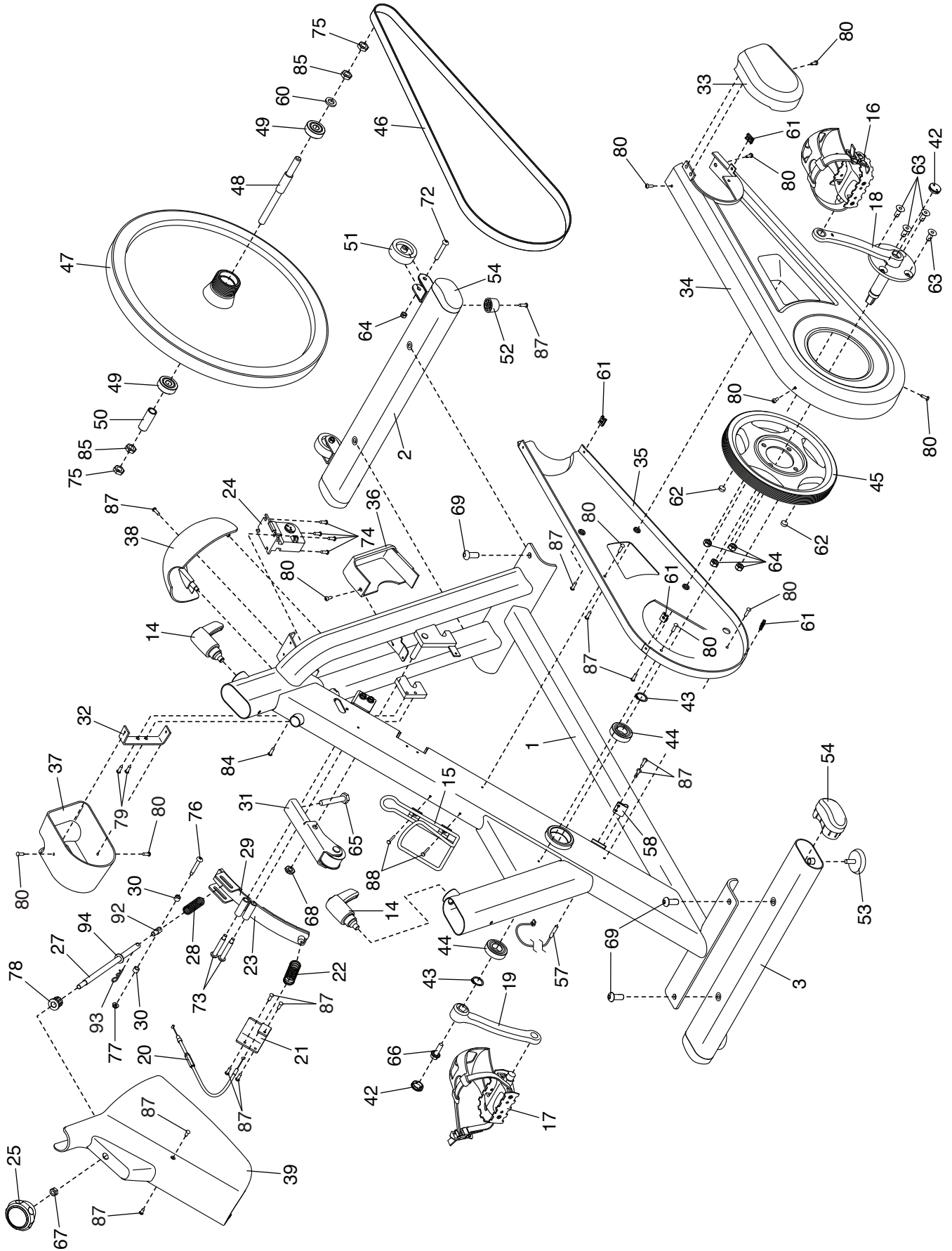

ORDERING REPLACEMENT PARTS

To order replacement parts, please see the front cover of this manual. To help us assist you, be prepared to provide the following information when contacting us:

- the model number and serial number of the product (see the front cover of this manual)
- the name of the product (see the front cover of this manual)
- the key number and description of the replacement part(s) (see the PART LIST and the EXPLODED DRAWING near the end of this manual)

RECYCLING INFORMATION

This electronic product must not be disposed of in municipal waste. To preserve the environment, this product must be recycled after its useful life as required by law.

Please use recycling facilities that are authorized to collect this type of waste in your area. In doing so, you will help to conserve natural resources and improve European standards of environmental protection. If you require more information about safe and correct disposal methods, please contact your local city office or the establishment where you purchased this product.

